

PROFILE A-A

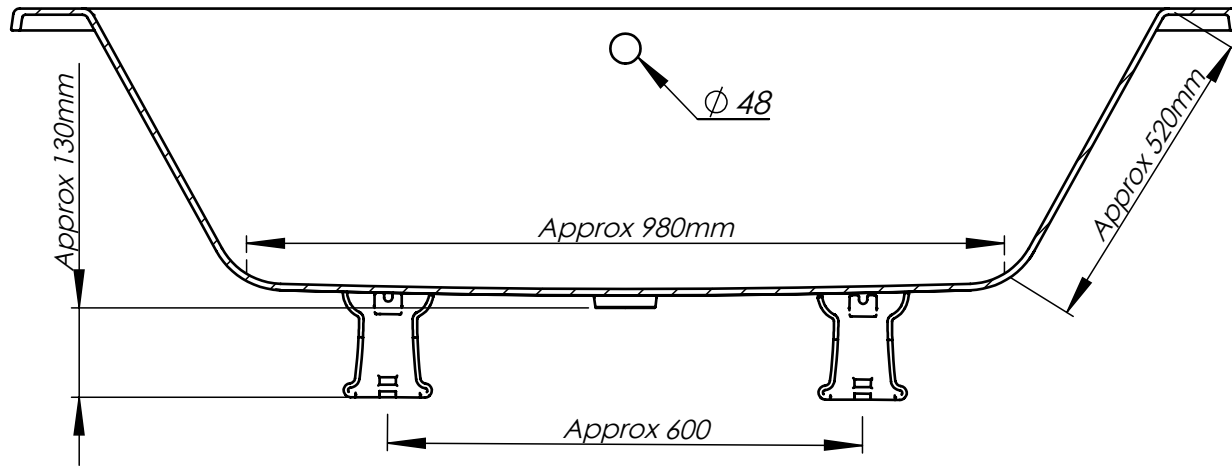

PROFILE B-B

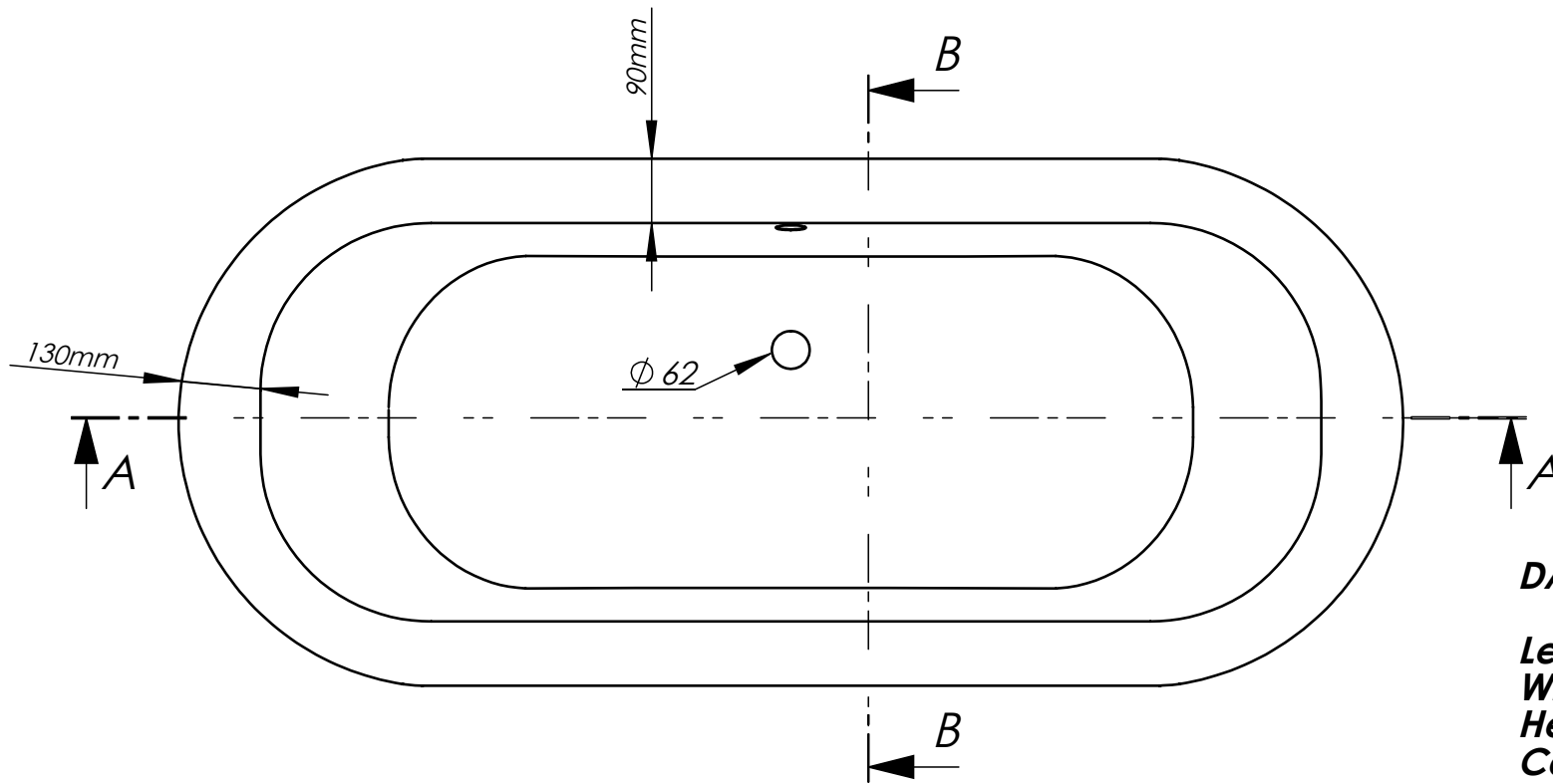
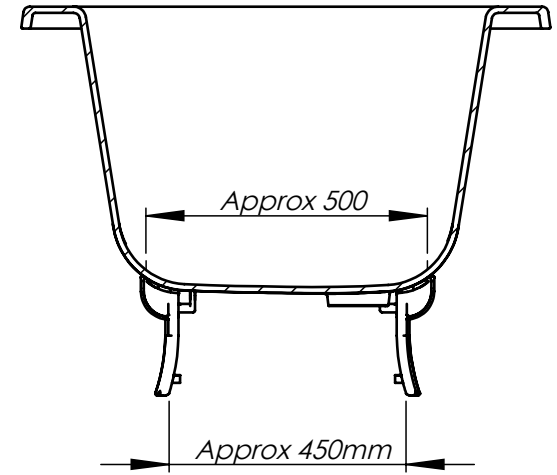

Crate measurements:  
 Length - 2005mm  
 Width - 950mm  
 Height - 760mm

**DAD 1012**

**Length: 1800mm**  
**Width: 880mm**  
**Height: 640mm (with feet)**  
**Capacity: 280 litres**  
**Weight without feet: 156 kg\***  
**Weight with feet: 164 kg\***

\* Due to hand made process weight can be up to 10 kg more